

M1C104

**CINTA Y HEBILLA A.C. INOXIDABLE
BAND AND BUCKLE
STAINLES STEEL**

NORMA DE FABRICACIÓN:
UNE 21-159 / ANSI 201 / ANSI 304

MATERIAL: Acero Inoxidable 201 ó 304
ACABADO: Natural, con brillo 2B sin filos cortantes

FLEJE INOXIDABLE					MÁXIMO ESFUERZO DE TRACCIÓN
CÓDIGO	DIMENSIONES (mm)		LONG.		
	ESPESOR	ANCHO			
M1C10418	0.8	12.7 1/2"	30.5 mts		700 Kg
M1C10416	0.8	19 3/4"	30.5 mts		1,000 Kg

HEBILLA INOXIDABLE	
CÓDIGO	MEDIDA
M1HE0000	12.7 1/2"
M1HE0001	19 3/4"

M1CR00

**CORREA PLÁSTICA DE AMARRE
PLASTIC BELT**

NORMA DE FABRICACIÓN: UL 94 V-2

MATERIAL: Nylon 66 resistente a los rayos UV

CÓDIGO	CARACTERÍSTICAS				
	A	B	COLOR	MAX. DIA. DE BUCLÉ (mm)	RESISTENCIA A LA TRACCIÓN
M1CR0035	120	4.8	NEGRO	30	8.2
M1CR0037	160	4.8	NEGRO	42	8.2
M1CR0012	203	4.8	NEGRO	74	13.6
M1CR0006	280	4.8	NEGRO	81	13.6
M1CR0005	368	4.8	NEGRO	102	22.7
M1CR0033	432	4.8	NEGRO	125	22.7
M1CR0021	914	4.8	NEGRO	270	22.7

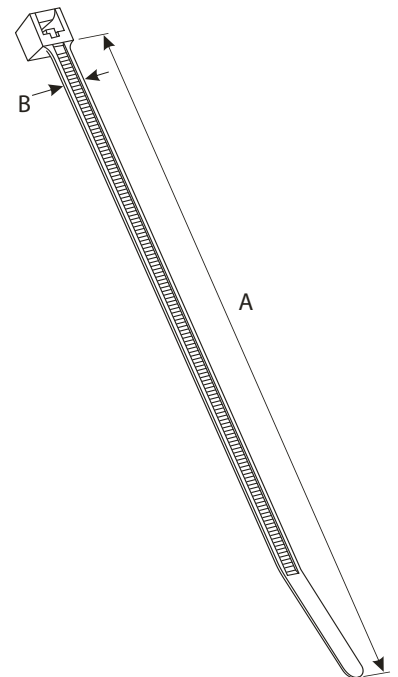

*Otras medidas y esfuerzos a la tracción, a requerimiento.